

- Anti-siphon
- Back pressure
- Pressure relief
- Pressure release
- For EXCEL™ AD and ROYTRONIC® P+ pumps

Bodies

- PVC and PVDF

Ratings

- 10 or 17.3 bar



New 4-Function Valve

For 800/900 series cartridge valve liquid ends

New 4-Function valve designed with advanced features

- Ergonomic design for easy control of functions
- Swivels 360° to the position best suited for the installation
- LMI's tubing connection system for the most secure connection available
- Hardware is protected from chemicals

FOUR FUNCTIONS

Anti-Siphon

The discharge flow path goes through a port that only opens on the discharge stroke of the pump. This prevents the discharge line from siphoning liquid from the supply tank in most applications.

Back Pressure

The diaphragm that controls anti-siphoning creates approximately 1.4 bar (20 psi) back pressure on the pump's discharge valve which improves system performance.

Pressure Relief

A second diaphragm protects the pump from overpressure by releasing fluid to a relief port in the event of excessive discharge line pressure.

Pressure Release

This function makes it easy and safe to depressurize the discharge line without loosening tubing or fittings.

MODEL NUMBERS

| VALVE NUMBER | WETTED MATERIALS | | | MAX. PRESSURE |
|--------------|------------------|-------------|-----------|---------------|
| | BODY | DIAPHRAGM | "O" RING | |
| 48753 | PVC | FLUOROFILM™ | POLYPREL® | 10 bar |
| 48754 | PVDF | | POLYPREL® | |
| 48755 | PVDF | | PTFE | |
| 48756 | PP | | PTFE | |
| 48798 | PVC | | POLYPREL® | 17.3 bar |
| 48799 | PVDF | | POLYPREL® | |
| 48800 | PVDF | | PTFE | |
| 48801 | PP | | PTFE | |

Valves supplied with a pump include connections as specified by pump model number. All valves sold as separate accessories are supplied with 3 m of 3*6 mm tubing.

Units with a solid black knob are rated for 10 bar (150 psi). Units with a black knob with a yellow insert are rated for 17.3 bar (250 psi).

CONNECTIONS

- To mount to a pump, remove the discharge fitting from the pump (if present) leaving the cartridges in the pump head.
Position the coupling nut (part 430 on diagram) on pump head over cartridges with threads up, and insert 4FV fitting (part 420 on diagram) and thread into pump head over cartridges. Tighten the fitting to 50 in-lbs using a 13/16" or 20 mm socket.
Insert the large opening on the 4-Function valve into the coupling knob and hand tighten. You can position the valve to have the bypass port in any convenient location by tightening the coupling nut with the bleed port positioned 90° counter-clockwise from desired location, then holding the nut stationary while turning the valve the final 90° to desired position.
- Connect 1/4" tubing to the bypass port and route to supply container.
- Connect discharge line using LMI tubing connection system or 1/2" pipe thread.

The New 4-Function valve is designed for double-ballchecks.

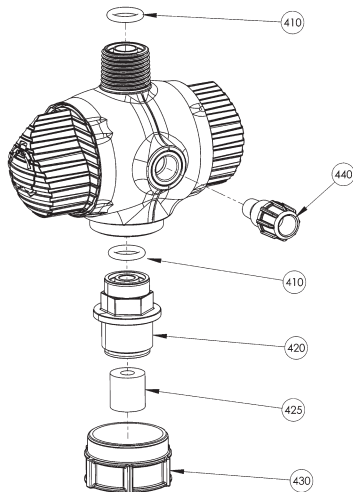

METHOD OF OPERATION

A. PRIMING

- Connect all tubing per instructions.
- Turn black knob about 1/8 turn counter-clockwise to stop point to open bypass port.
- Set pump at 100% speed and 100% stroke length. Start pump.
When fluid has been flowing through the bypass port tubing for 10-20 seconds, the pump is primed.
- Stop pump and return black knob to normal position.

Note: The pumps are normally self priming if suction lift is less than 1.5 meters (5 feet) check valves are wet (there is usually water in the pump head when shipped from the factory), and the steps above are followed. If the pump does not self prime, you can choose one of 2 ways to help prime:

- Remove the 4-Function valve and discharge cartridges and slowly pour water or solution into the pump head until it is filled. Replace cartridges and 4-Function valve and repeat steps above.
- Or, temporarily improve suction conditions by pumping from a container closer to or above pump.

B. DEPRESSURIZING THE DISCHARGE LINE

When preparing to maintain the pump or any component in the discharge line, the 4-Function valve is used to depressurize the line. Be sure an injection check valve is properly installed and is operating, and that all tubing connections on the 4-Function valve are secure.

- Turn off the pump.
- If any valves have been installed downstream of the pump, close them.
- If the supply tank for the pump is higher than the pump head, fluid will flow through unless a suction line valve is closed.
- Turn the black knob on the 4 function valve about 1/8 turn counter-clockwise to its open position. This relieves pressure between the pump and the 4-Function valve.
- To release line pressure, while the black knob is in the open position, turn the yellow knob and hold open until fluid flow through the bypass port stops.



PSR: 30 Chemin de St Germain 77450 Esbly Tel : 09 67 07 06 79 - @ psr-robinetterie@orange.fr

